

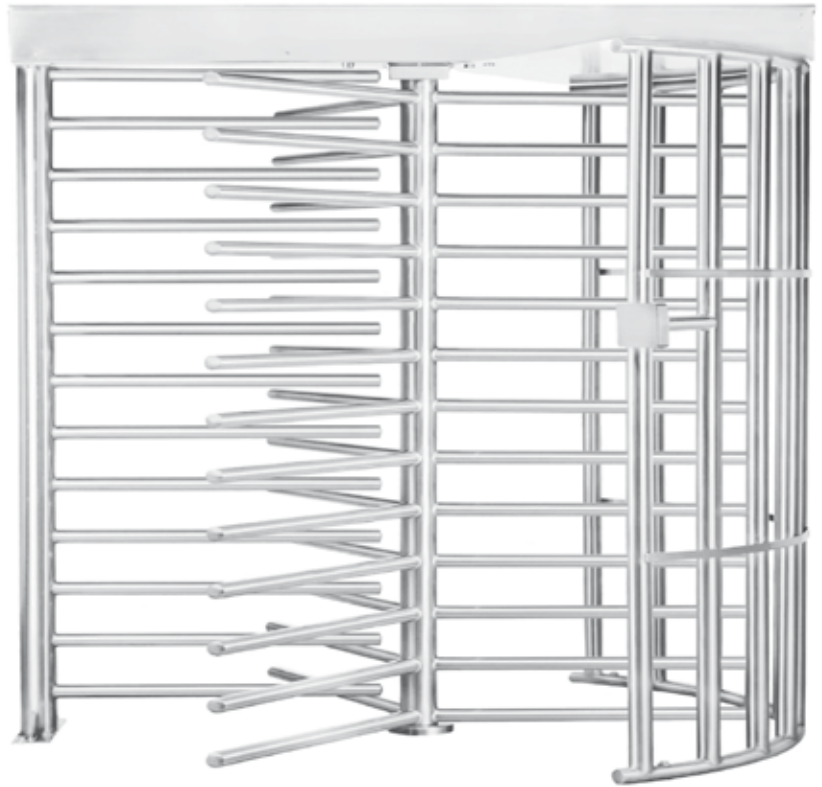

model **MST47**

DESCRIPTIVE SPECIFICATIONS

The MST47 is the extended arm version of our trusted and reliable full height MST. Its 47" arms provide the flexibility of a wider passage area.



COMMON APPLICATIONS

- Perimeter Control/ Fence Line Security
- Time & Attendance Integration
- Loss Prevention
- Employee and Visitor Access Control
- Unmanned Point of Entry
- Single Direction Traffic Control/ One-Way Exiting

TYPICAL INSTALLATION SITES

- Military Installations
- Refineries & Power Distribution Centers
- Ports, Harbors & Airports
- Construction Sites
- Correctional Institutions
- Manufacturing & Distribution Centers
- City Parks & Recreation Sites
- Sports Parks, Arenas & Stadiums
- Zoos & Amusement Parks

FUNCTION

MST47 turnstiles are designed to control access into and out of facilities. Among its many attributes, the MST47 comes with self-adjusting, self-centering, speed control. This highly unique feature ensures a consistently even rotation, and smoothly self-centers the turnstile, under all conditions. The MST47 is suitable for indoor or outdoor use. Contact Alvarado for recommendations on finishes and specific weatherization options for harsh environments.

AVAILABLE CONFIGURATIONS

MST47-3 (manual control)

Using key lock control, the MST47-3 can be configured to provide free passage in both directions; free passage in one direction and restricted passage (locked) in the opposite direction; or restricted passage (locked) in both directions.

MST47-6X (electric lock control)

Provides separate electric lock controls for both directions. The key lock override controls described in the manual control unit above are included. The MST47-6X interfaces with virtually any access control system.

AVAILABLE FINISHES

GALVANIZED

All exterior steel materials are hot-dip galvanized to ASTM Standards A123 / A153. Galvanized units, like all Alvarado MST47's, have stainless steel Top Channel covers.

POWDER COATED

All exterior steel materials are powder coated. Powder coating is available in a variety of colors.

STAINLESS STEEL

All external materials are fabricated from #304 stainless steel polished to a #4 satin finish. Welds are electropolished to ASTM Standard E1558.

MATERIALS

TOP CHANNEL

The exterior housing is fabricated from 16-gauge #304 stainless steel, regardless of finish. The interior Top Channel frame is a 7" wide U-frame fabricated from 4-gauge powder coated steel. The Top Channel houses the control mechanism and electrical components.

YOKE GUARD PLATE (COVER)

A 16-gauge steel (or #304 stainless steel) sheet securely fastens to the Top Channel & Yoke.

YOKE (CURVED SECTION)

The Yoke is a fully welded single assembly consisting of 16 vertical tubes notched and welded to two upper and lower horizontal tubes. Two 0.1875" x 1" steel straps are welded to the vertical tubes for support. Vertical and horizontal tubes are fabricated from 1.75" OD x 16-gauge steel (or #304 stainless steel) tubing. No external fasteners are used in the construction of the Yoke.

ROTO (ROTATING SECTION)

The Roto is a fully welded single assembly consisting of 13 arms per section (total of 39 arms per Roto) notched and welded to a vertical tube. Arms are fabricated from 1.75" OD x 11-gauge steel (or #304 stainless steel) tubing. Arms have either a welded metal cap (powder coated or stainless steel models) or a ribbed, force fit plastic cap (galvanized models). The vertical tube is fabricated from 3" OD x 6-gauge steel (or #304 stainless steel) tubing. No external fasteners are used in the construction of the Roto.

OV (BARRIER SECTION)

The OV is a fully welded single assembly consisting of 13 arms notched and welded to a vertical tube. Arms are fabricated from 1.75" OD x 11-gauge steel (or #304 stainless steel) tubing. Arms have either a welded metal cap (powder coated or stainless steel models) or a ribbed, force fit plastic cap (galvanized models). The vertical tube is fabricated from 3" OD x 6-gauge steel (or #304 stainless steel) tubing. No external fasteners are used in the construction of the OV.

MECHANICAL COMPONENTS & FUNCTIONALITY (ALL MODELS)**HYDRALINE™ SPEED CONTROL & SELF-CENTERING MECHANISM**

HydraLine is Alvarado's revolutionary speed control that self-adjusts to the pushing force of the user to ensure a safe, controlled and quiet rotation. Self-centering automatically corrects under- or over-rotation of the turnstile arms following a passage cycle and automatically returns the arms to the "home" position in a controlled fashion.

INDASPLINE™ - CAM AND SHAFT ASSEMBLY

The cam and shaft assembly consists of a stainless steel, investment cast lobed cam welded to a splined shaft. The splined shaft fits into a reciprocal splined coupling in the top of the Roto, creating a solid non-slip connection that ensures very precise movement and reduces mechanism wear. Our design makes it mechanically impossible to improperly install the Roto (rotating section) of the turnstile.

TURNSTILE LOCKING CONTROL

The locking and unlocking of the unit is controlled with stainless steel lock arms that are moved into the appropriate locked or unlocked position by continuous duty rated solenoids and spring assemblies. There is independent control of each rotational direction.

ENCLOSED BEARING ASSEMBLIES

The cam and shaft assembly rotates in a bearing assembly consisting of two outdoor rated precision bearings. The lower bearing is protected by a sheet metal cover.

CARD READER PLATE RECEIVERS

All 6X models come with card reader plate receivers on both entry and exit sides of the Yoke. Card reader adapter plates are available to fit virtually any commercially available reader (see Options).

ELECTRICAL COMPONENTS & FUNCTIONALITY (MST47-6X MODELS)**TURNSTILE CONTROL BOARD**

The Alvarado Turnstile Controller (ATC) controls activation and turnstile functions. Activation for either direction of operation is achieved by supplying a momentary dry contact of any duration to the ATC.

REMOTE UNLOCKING

Each ATC accepts inputs from a continuous dry contact emitting device to bypass the access control system and allow the MST47-6X to be remotely unlocked in the electrically controlled direction(s).

OPTO-INTERRUPTOR DETECTION ASSEMBLY

Rotation of the turnstile is detected by an internal opto-interruptor assembly. No mechanical microswitches are used in the operation of the turnstile.

ADJUSTABLE TIMED DELAY AUTO RE-LOCK

This feature adjusts the time a user is allowed to pass through the turnstile after activation, before the turnstile automatically relocks. There are multiple adjustment settings, or the timed delay auto re-lock feature may be disabled.

INDEPENDENT TURNSTILE TESTING

The turnstile control board allows the unlocking function to be tested independently of the access control system. This is ideal for troubleshooting.

FAIL-LOCK/FAIL-SAFE CONFIGURATION

The default configuration for MST47-6X turnstiles is fail-lock (entry)/fail-safe (exit). Other configurations are available. Field changes can be accomplished quickly and easily by a qualified technician without replacing the Top Channel.

OUTPUTS**FEEDBACK / TURNSTILE ROTATION COUNT**

The ATC provides a double pole, single throw, relay in each direction of operation when a rotation occurs. This signal serves as “feedback” to the access control provider, indicating a rotation has occurred, or as a “count” to an external counting system.

OPTIONS**RED/GREEN ACTIVATION LIGHTS***

Available for use with the MST47-6X. A red and green LED array located in the Top Channel is configured to function in the following manner:

Red Light - An illuminated red light indicates the turnstile is locked and ready for card presentation.

Green Light - An illuminated green light indicates the access system has provided the ATC with an activation indicating an “authorized” card has been presented. When the green light illuminates, the turnstile will unlock.

RED/GREEN/YELLOW ACTIVATION LIGHTS*

Available for use with the MST47-6X. A red, green and yellow LED array located in the Top Channel is configured to function in the following manner:

Red Light - An illuminated red light indicates the access system has provided the ATC with an activation indicating that an “unauthorized” card has been presented. The turnstile will remain locked.

Green Light - An illuminated green light indicates the access system has provided the ATC with an activation indicating an “authorized” card has been presented. When the green light illuminates, the turnstile will unlock.

Yellow Light - An illuminated yellow light indicates the turnstile is locked and ready for card presentation.

*Photos depicting light options may be found at www.alvaradomfg.com

OPEN/CLOSED STATUS LIGHTS*

Red and green LEDs are available to indicate whether the turnstile is open or closed. LEDs are installed in the Top Channel for easy visibility. This option is used in conjunction with remote unlocking (see electrical functionality).

FAIL-SAFE/FAIL-SAFE OPERATION

Both sides of the turnstile will unlock upon loss of power and provide free passage in both directions. The MST47-6X unit is supplied in a fail-lock (entry)/fail-safe (exit) mode as default.

FAIL-LOCK/FAIL-LOCK OPERATION

Both sides of the turnstile will remain locked upon loss of power. Key overrides (which are standard) can still be used to unlock the turnstile. The MST47-6X unit is supplied in a fail-lock (entry)/fail-safe (exit) mode as default.

CARD READER ADAPTER PLATES

6"x6" adapter plate fits most card readers and allows mounting to reader mounting posts on 6X models. Custom plates are available. Contact Alvarado for more information.

READER PLATE RECEIVER COVER

A small aluminum plate used to cover an unused reader plate receiver.

OUT OF SERVICE LOCK BRACKET

Enables the turnstile to be secured with a padlock when the turnstile is out of service.

HEEL/ARM GUARDS

Padded sleeves for arms at pushing level or for lower Roto arms. Heel/Arm guards are packaged three to a set.

ELECTRIC LOCK CONTROL UPGRADE (MODEL MST47-3 UNITS ONLY)

All Model MST47-3 units are convertible to electric lock control. MST47-3 Top Channel frames include brackets and insertion holes to allow for easy field retrofit by a qualified technician.

220VAC

A 220VAC, 50-60 Hz transformer is substituted for the standard 110VAC transformer. 220VAC units bear CE marking, except for battery backup capability which is not available on CE marked units.

PUSH BUTTON ASSEMBLY

Unlocks the turnstile for one passage with a stainless steel push button assembly.

BATTERY BACKUP

A trickle charge battery system is installed in the Top Channel to provide limited duration operation if primary power to the turnstile is lost. Not available on CE marked units.

TOP CHANNEL STABILIZER

A Top Channel stabilizer can be provided to increase rigidity between the OV and the Top Channel.

INTERFACE COMMUNICATION OPTIONS

Alternate communications methods are available, including serial and TCP/IP. Contact Alvarado for more information.

DUST PROTECTION

Additional protection measures are added to the Top Channel for extremely dusty installation environments. Contact Alvarado for more information.

*Photos depicting light options may be found at www.alvaradomfg.com

SHIPPING & SITE PREPARATION

SHIPPING

MST47 turnstiles are shipped in five main sections: the Top Channel, the Yoke, the Roto, the OV and the Yoke Guard Plate. Each section is fabricated as a sub-assembly for easy installation.

SITE PREPARATION

All turnstiles must be installed on a firm foundation in a manner that allows the required power and activation signal cabling to be pulled into the Top Channel. Optional conduit may be run through the OV base. The recommended slab platform is 120" x 102" x 4" deep, level concrete. Concrete anchors, bolts and washers are included with each turnstile. Installation should be performed by a skilled installer following Alvarado's directions and instructions. Detailed drawings and installation manuals are available online.

TECHNICAL DIMENSIONS

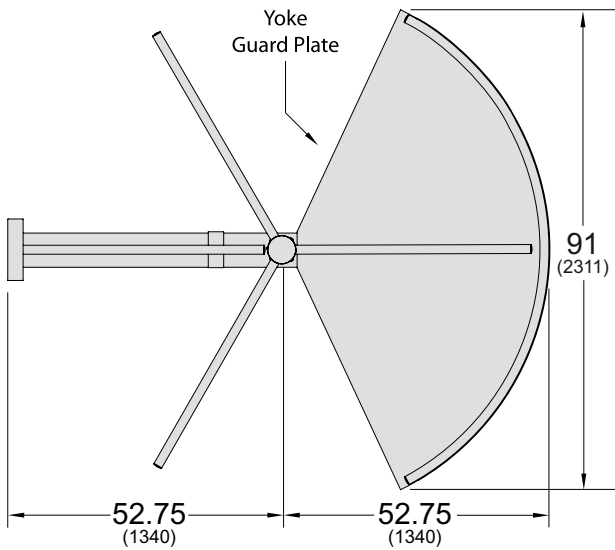

Dimensions shown in inches (mm)

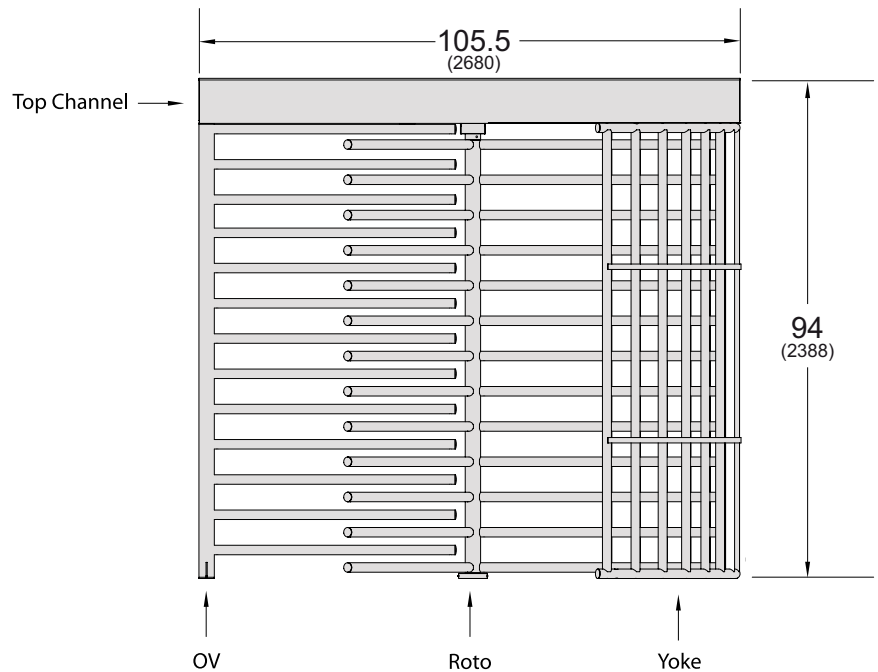

ELECTRICAL	
	DESCRIPTION
TRANSFORMER	110VAC, 50-60 Hz. Low voltage primary power of 10 VAC or 13.5 VDC may also be supplied by connecting power directly to each ATC.
POWER REQUIREMENTS	Max power consumption is 65W per turnstile with all available electrical options.
OPERATIONAL VOLTAGE	Primary power is stepped down and rectified for low voltage 12VDC/5VDC operation.
ON/OFF SWITCH	An on/off switch is located on each power junction box inside the MST47-6X Top Channel. A visible green LED is illuminated on the ATC when the power is "on."
POWER RECEPTACLES	The power junction box inside the MST47-6X Top Channel includes two 110VAC power receptacles providing a convenient way for installers or technicians to power tools or equipment used during installation and maintenance of the MST47-6X.
SURGE PROTECTION	Each ATC uses a ceramic varistor for transient voltage suppression up to 80 amps for low voltage AC inputs. Control signal lines are protected by bi-directional transient voltage suppression diodes up to 600W per input. This combination provides superior lightning and surge protection.
BI-DIRECTIONAL SOLENOID DRIVERS	Each ATC provides one solenoid driver per rotation direction.

WEIGHT, DIMENSIONS, ENVIRONMENT		
	STANDARD	METRIC
PRODUCT WEIGHT	900 lbs.	410 kg
SHIPPING WEIGHT*	1300 lbs.	591 kg <small>*Includes weight of shipping crate(s).</small>
HEIGHT	94"	2388 mm
WIDTH	105.63"	2683 mm
DEPTH	91.38"	2321 mm
OPERATING TEMPERATURE	-20° to 150° F	-29 to 66° C
STORAGE TEMPERATURE	-30° to 160° F	-34 to 71° C
RELATIVE HUMIDITY	0-90% (non condensing)	--

WARRANTY

For a period of one year from the date of purchase, Alvarado will replace or repair, at Alvarado’s option, any products or parts which are defective in materials or workmanship, provided recommended installation and maintenance procedures are followed. This warranty is void if damage is due to improper installation, maintenance or use. This warranty is limited to parts only, and does not cover labor or shipping charges incurred in connection with the removal or replacement of warranted products or parts.

This warranty is expressly made in lieu of any and all other warranties, expressed or implied, including, but not limited to implied warranties of merchantability and fitness for a particular purpose. Alvarado shall not be liable for any loss or damage, directly or indirectly, arising from the use of purchased products. In no event shall Alvarado be liable to buyer for consequential damages, special damages, incidental damages, loss of use, business interruption, loss of profits, or damages of any kind arising out of the use or inability to use a purchased product. In NO event shall Alvarado be liable for damages which exceed the purchase price of a covered product.

